

SORRENTO™



Martina Tierney

Occupational Therapist & Creator of the Sorrento

“Since becoming an Occupational Therapist 30 years ago, I’ve worked to improve the quality of people’s lives through seating, and every day I see their lives dramatically changed as a result. The results are amazing”



THE ONLY CHAIRS SUPPORTED BY COMPREHENSIVE CLINICAL EVIDENCE

Download the full research summary here: **Seating Matters Ulster Research Summary**

The significant results* have demonstrated what we already believe, that the correct use of clinical, therapeutic seating can lead to:

- ✓ Pressure injury reduction.
- ✓ Improved posture and function.
- ✓ Reduced sliding and falling from chairs.
- ✓ Reduced time spent in bed.
- ✓ Improved comfort and quality of life.
- ✓ Reduced expenditure on staff and resources.

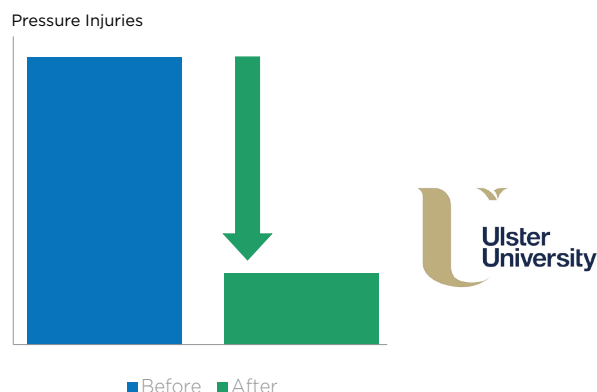

*Please review full details - <https://www.seatingmatters.com.au/clinical-benefits/>

THE FOUR PRINCIPLES OF PRESSURE MANAGEMENT IN SEATING

1. Load the Body

Ensure full body is in contact with the chair to redistribute pressure off bony prominences. Don't forget to load the feet! 19% of body weight goes through our feet.



2. Provide Postural Support

Posture and pressure are inextricably linked. Support any fixed or flexible deviations in posture with the correct seating and accessories to avoid uneven pressure redistribution.

3. Effective Repositioning

Guidelines recommend that seated individuals are repositioned every two hours to increase blood flow to skin. Functions such as tilt in space and back angle recline make this easier.



4. Appropriate Surface

All weight bearing parts of the chair should facilitate immersion, envelopment and support of the patient's body. The Seating Matters chairs are made up of Dartex covered pressure redistributing foam.



The Sorrento chair helps people needing high levels of pressure care, comfort and posture support. It is suitable for people in any setting, including hospitals, care facilities or their own home.

For people with high pressure care needs, the tilt in space can be used to improve posture and redistribute pressure. The tilt movements include forward tilt to assist standing transfers for rehabilitation or in self transferring situations. The adjustable back recline will help people with limited hip flexion and when used in combination with tilt in space it can prevent sliding from the chair.

The Sorrento is modular and can be adjusted to fit people of many shapes, sizes and care needs. The seat width, seat depth and foot plate height can all be customised on site.

Being completely mobile, the Sorrento can be moved throughout a home, allowing the user to maintain interaction with family and friends while relaxing in a comfortable, safe chair.

The Sorrento uses high pressure care materials on all contact surfaces and tilt in space for re-positioning.

Optional lateral supports and supportive pillows can help to maintain or improve posture and facilitate functional ability in activities of daily living such as eating and communicating. The correct use of these features and clinical accessories can also reduce common problems such as falling to the side when seated.

Suitable For These Conditions

- ✓ Cerebral palsy
- ✓ Spinal cord injury
- ✓ Head injury
- ✓ Stroke
- ✓ Multiple sclerosis
- ✓ Parkinson's disease
- ✓ Motor neurone disease
- ✓ Dementia
- ✓ Alzheimer's disease

MAIN USES

NDIS / Home Care - Care Facilities

Suitable for highly dependent people with complex seating needs. The Sorrento is often used as an alternative seating system for wheelchair users while still providing postural support and pressure care. Being completely mobile, the Sorrento can be moved throughout a home, allowing the user to maintain interaction with family and friends while relaxing in a comfortable, safe chair. For people with degenerative conditions, the Sorrento can be adjusted as needs change.

Hospital

Useful for those in high dependency wards at risk of pressure injury and requiring high levels of postural support. Eg; HDU ward, surgical wards, general medical wards, geriatric medicine, stroke and neuro, transitional care and acute care.

The Sorrento Chair Has:



*Items are Optional.

Valerie Sitting In A Sorrento



BEFORE



AFTER

To learn more about Valerie's Story, visit the case study here:
<https://www.seatingmatters.com.au/seating-range/sorrento/#case-studies>

Sorrento Chair Features:

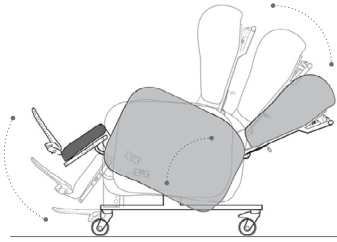

Tilt in space (45 degrees - dependant on chair model) to allow for re-positioning for pressure care and comfort of the user. Elevating leg rest and recline are also standard.

Dartex multi stretch pressure management materials throughout all patient contact surfaces. This material is breathable with moisture permeability to ensure that the surface remains dry and comfortable for the user. This material can be wiped down for infection control and hygiene requirements.



Medium to high pressure management cushion, using memory foam. This cushion is removable for cleaning and if you wish to use a different type. An advantage of our memory foam cushions is they do not require maintenance or adjustment for each person, unlike a gel or air cushion. The cushion is also easily replaceable.

Adjustable seat width, foot plate height and seat depth allows the chair to fit the size and requirements of the user.



Removable and height adjustable arm rests.

Available in manual or electric combinations.

Sorrento Parts & Accessories

Ramped Seat Cushion



Pressure Management Arms



Padded Arm Covers (1", 2")

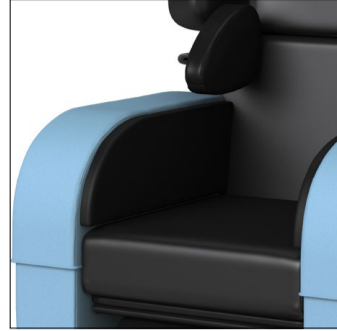

Removable Seat Cover



Tray Table



Lateral Supports



Leg Laterals



Leg Rest Wedge

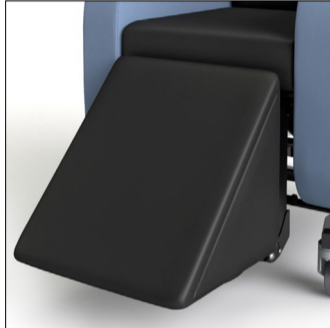

Padded Footplate (1", 2")



Horseshoe Pillow



Head Pillow



Concave Pillow



Removable Arm Covers

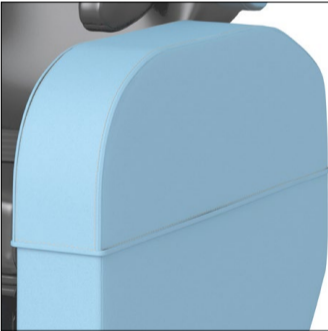

Seat Belt

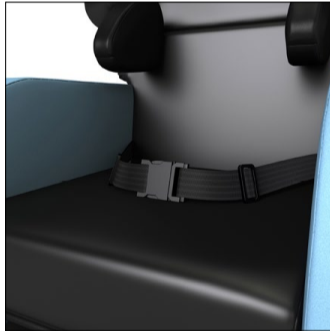

Padded Seat Belt Cover



4 Braked Castors on Chair

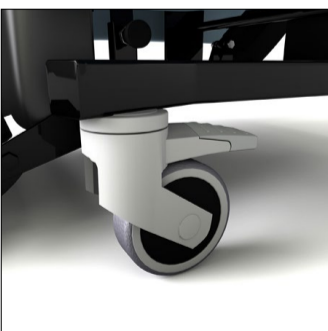

Stroller Wheels



NexTier Cushion

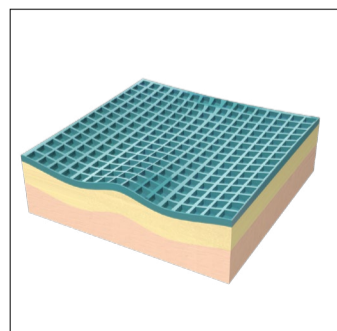

AirTier Cushion



Other Accessories - Sorrento

- ✓ Soft Fibre-filled Footplate
- ✓ Pelvic belts to provide support to the hips

Sorrento Technical Specifications

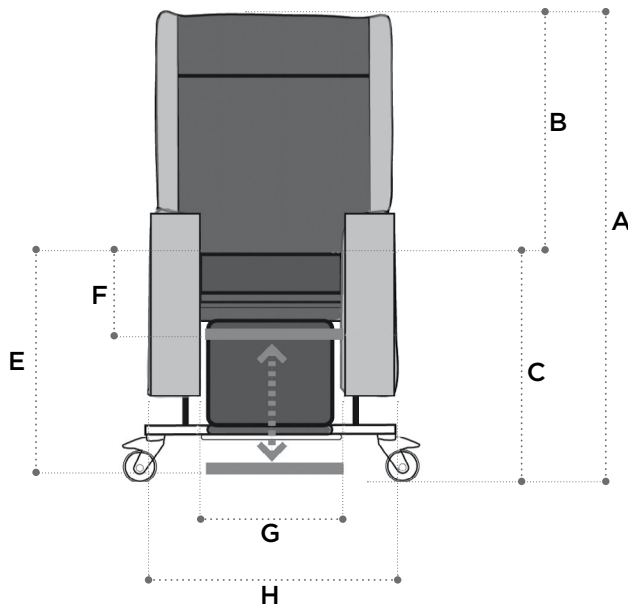

Basic dimensions

A	Overall height	1320mm/52in
B	Back height	750mm/30in
C	Seat height	600mm/24in
D	Overall Length	1200mm/47in

Footplate height adjustments

E	High	300mm/12in from seat
F	Low	510mm/20in from seat

Available seat and overall widths

G (Seat width)	H (Overall width)
350mm/14in*	640mm/25in
400mm/16in	640mm/25in
450mm/18in	670mm/26in
500mm/20in	720mm/28in
550mm/22in	770mm/30in
600mm/24in	820mm/32in

* This seat width is achieved using a 400mm/16in seat and a set of 25mm/1in padded arm covers.

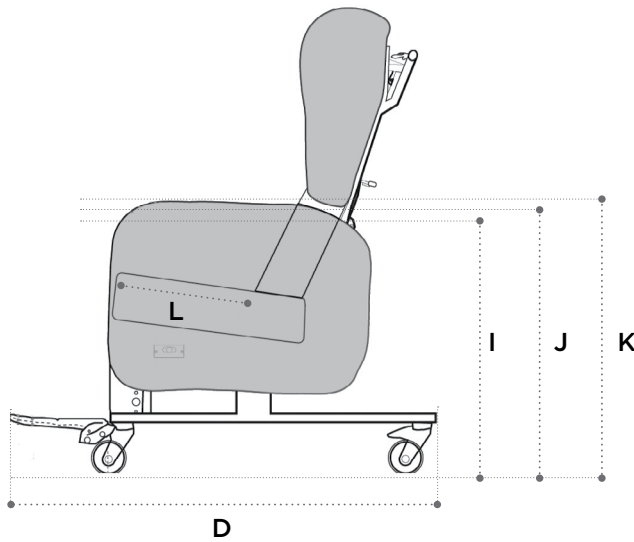

Arm height options

I	Low	715mm/28in
J	Medium	740mm/29in
K	High	765mm/30in

Seat depth

L	See page 9
----------	------------

Recline and tilt angles

ii Back angle recline

90° - 130°

40° range

iii Leg rest angle

90° - 125°

35° range

iv Tilt in space

From 5° forward, or anterior, tilt to 30° or 45° backward tilt (dependent on chair model).

Chair weight unloaded is 62 Kg/136.68 lb/9.7 Stone.
Chair user weight limit is 159 Kg/364 lb/25 Stone



Infection Control

Infection prevention is vitally important in the home, hospital and healthcare environments. Bacteria and germs often contribute to the development and spread of infections. They can potentially be very harmful so this is important to control and prevent, especially in areas such as hospitals, where patients may be vulnerable and susceptible to infection.

Seating Matters take infection control very seriously. Our chairs have been specifically designed to decrease entrapment areas where bacteria and germs can survive.

Dartex Multi-stretch (Patient contact surface). Waterproof, stain resistant, flame retardant, multidirectional stretch for pressure redistribution i.e. seat cushion, calf panels, lateral supports and seat back.

BELOW ARE SOME OF THE STEPS WE HAVE TAKEN TO PREVENT THE SPREAD OF INFECTIONS:

- ✓ All chairs are upholstered in a hard-wearing, enduring contract vinyl proven to counteract C.diffidile, E.coli as well as MRSA and the vast majority of bacteria.
- ✓ The materials can all be cleaned with hospital-grade cleaning agents, without causing damage to the fabrics. Please refer to the instructions on the specific cleaning solution you intend to use for best results.
- ✓ The arms on the Sorrento are removable so that the seat and lower back area can be wiped clean.
- ✓ The seat cushion is removable for ease of cleaning.
- ✓ The seat cushion is attached to the base of the chair with a non-slip, wipeable material therefore having no materials such as Velcro which can hold dirt and bacteria.
- ✓ All electric components are part of a sealed unit which can be wiped clean.
- ✓ The metal frames of the chairs have a powder coated finish which is electro-statically applied then cured under heat to allow it to form a "skin". The powder is a thermoset polymer and is used to create a hard finish that is tougher than conventional paint, therefore protecting the frame from being exposed to outside conditions and thus preventing rusting.
- ✓ All chairs have modular parts which means the chair can be completely dismantled leaving no areas unexposed for cleaning.
- ✓ The complete chair frame is designed with flat panels throughout which can be easily wiped clean.
- ✓ Dartex Multi-stretch Fabric (Patient contact surface). Properties: This fabric is waterproof, has the ability to be wiped clean and has biostatic (anti-mycotic) coatings to provide an impenetrable barrier to virus and bacteria.



Build Quality

It takes continuous, careful planning to ensure our chairs are functional as well as being aesthetically pleasing. Our design team are adamant that the chairs need to be designed in such a way that they fit into a home environment. Each and every part of a Seating Matters chair has been engineered and devised to offer optimum quality and support for the user.



EASE OF USE

All Seating Matters chairs can be adjusted without tools in less than one minute. Useful to easily and efficiently adjust the chair to suit the user or to readjust for use within a multi-user environment.



7 YEAR WARRANTY

Have total peace of mind when relaxing in a Seating Matters chair as each one has passed some of the world's most stringent standards for strength, durability and safety. That's why we can uphold an industry leading 7 Year Frame warranty on the Phoenix chair with total confidence. Some terms and conditions apply, see our 7 Year Warranty booklet for full details.

Seating Matters are an ISO 9001 Quality Management System approved company.

Seating Matters chairs are registered with the TGA – ARTG-246892



SEATING MATTERS CHAIRS ARE USED BY:



On NSW Health Contract
HSSP_HC19_CF820



Standard Fabric Options



Rivera Menton



Rosso Red



Ocean Blue



Cobalt Black



Grape Purple



Taurus Cream



Mocha

Other colour options are available for volume purchases.

About-us

Hello, I'm Martina Tierney,
I am an Occupational Therapist, Author, Educator and the Clinical Director of Seating Matters.

Throughout my 30 year career, I have worked in acute and community care, nursing homes and rehab, specializing in clinical seating provision. During my time working with patients, I discovered the profound effects poorly designed seating could have on patient outcomes and struggled to find chairs which met their clinical and functional needs.

After outlining the different features my patients required, including pressure care and easy adjustability, I set the goal to change the world of healthcare seating, by designing therapeutic chairs that would meet needs of bed-bound and low mobility patients.

WHY SEATING MATTERS

It is sometimes hard for an able-bodied person to understand what it feels like to be sitting for long periods of time and how this affects your life sitting in a poorly designed chair. An able-bodied person can easily and unconsciously re-adjust their position before getting too uncomfortable.

As a comparison, think of the discomfort when you are sitting on a long-haul flight. You will get up and walk around to reduce any pain. This shows that a standard chair is not suitable for long term sitting.

Now imagine doing a long-haul flight every single day of your life.
That is what some people experience every day in their own homes, hospitals or care facilities and many haven't got the ability to change their own position!

That is why getting the right chair for the right person is so important.

Even today, too many people continue to experience pain because of poor posture and poorly designed seating. Too many people are suffering a reduced quality of life from avoidable pressure injuries. Also far too much money is being spent by health services worldwide on reacting to these problems after it is too late.

Clinical, functional seating can help solve these problems.

As author of 'The Clinician's Seating Handbook' amongst other titles, I continue to research to find new solutions to seating challenges and help to educate audiences throughout the world on my findings.

Today, Seating Matters is changing the world through healthcare seating by improving the knowledge available to the healthcare community and by continually pushing the boundaries of seating innovations.

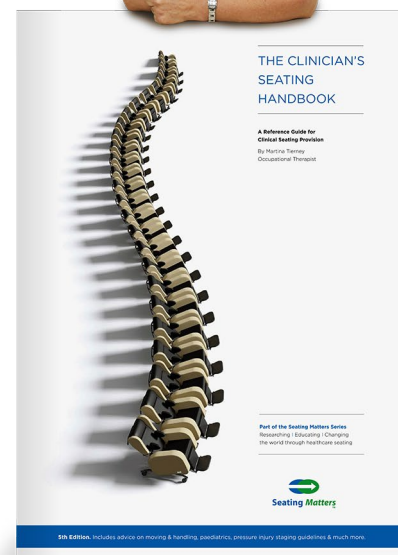

To request a copy of The Clinicians Seating Handbook visit:
www.seatingmatters.com.au

“Each day I realise more and more the impact of seating on people’s lives. For these people, the quality of their chair determines the quality of their life.”

— Martina Tierney, OT

Seating Matters Australia
9/256 New Line Road
Dural NSW 2158 Australia

Phone: 1300 001 050
Email: ausoffice@seatingmatters.com



Seating Matters
TM

www.seatingmatters.com.au